

# S6 4G Video Door Phone

## Quick Installation Guide

www.alarmsecur.com

## Quick Installation

### Install Software

- Search for LiveCloud in the App Store or Google Play.
- Download the LiveCloud app.



### Insert 4G SIM card

**Note:** Have your 4G SIM card before installation.

- Make sure your 4G SIM is valid.
- Insert 4G SIM Card to SIM socket.

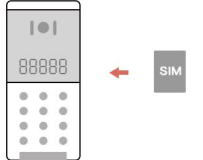

### Connect the power cord

- Plug the power cord's 2 Pins port into power port.
- Plug the power cord's DC port to 12V-18V DC power adapter.

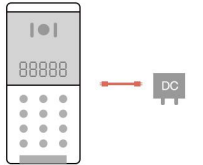

### Launch the LiveCloud app

- Launch the LiveCloud app.
- Sign in your phone number account with SMS code or password.
- Set a new password for the first login.

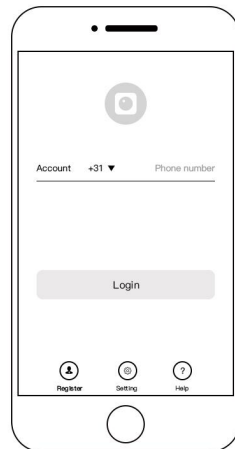

### Add the 4G door phone

- Tap + and select **Add 4G device**.
- Input device ID and password.
- Follow the instructions in app to name the door phone and its location.

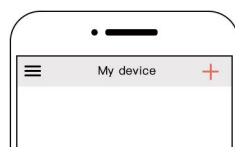

**Note:** Tap **Detail** to check the detail info of device and name it.

## Operation

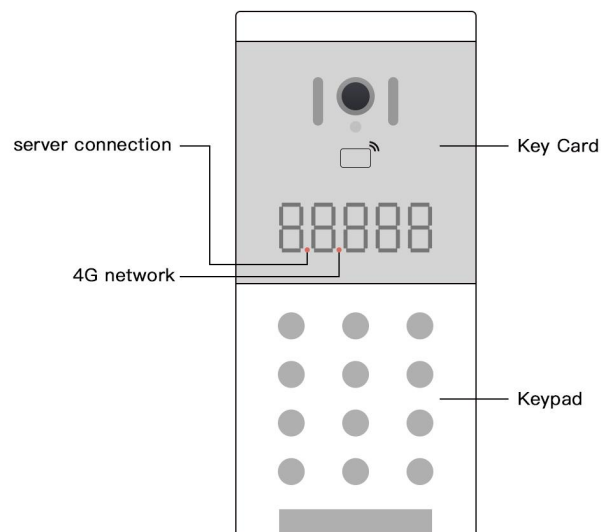

### Connection LEDs

- The LEDs indicate 4G network and server connection status:

ON	disconnected
OFF	connected

## Keypad

- Room number
  - Press the key to input a digit Long press the key to enter/exit the alphabet mode, short press to select an alphabet, press any other key to input the alphabet.
  - Press # to delete the input.
  - Input 5 letters room number to video call.
  - Press # to end the call.
- PIN code
  - Press \* to enter PIN code input mode.
  - Input 5 digits PIN code to unlock the door.
  - Press # to delete the input.
- Phone Number
  - Long press \* to enter phone number input mode.
  - Input phone numbers and end with \* to voice call.
  - Press # to end the call.

## Key Card

- Select a room in app to add a new key card.
- can a new key card 2 times in 60 sec.
- Show the key card ID if success.
- Scan the key card to unlock the door.

- Add key card to the room
  - Press a room number to select a room.
  - Press + button and select **Key card**.
  - Scan a new key card 2 times in 60 sec.

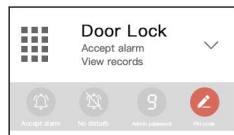

## Add PIN code to the room

- Tap the arrow button on the right side of the smart lock.
- Press **PIN code** button.
- Press + button and select a room.
- Input 5 digits PIN code and Tap **OK**.



## Answer video call and unlock the door

**Note:** Allow notifications of App on your phone, and enable display notification on banners.

- Press  button to answer a video call.
- Press  button to select a lock and Tap **Unlock**.
- Press  button to hang up the call.

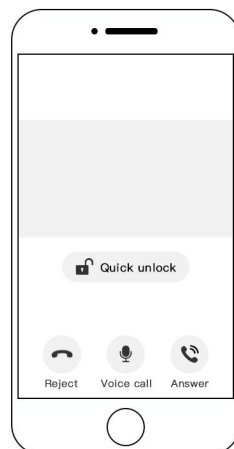

## Reset

- Recover to factory setting and clean all data of PIN code and key cards.

## SD card

- You can insert a compatible SD card, up to 128GB. It stores 24/7 video and auto loop cover old video.

## App Overview

### Add the residents

- Press **Resident** button.
  - Add room
    - Press + button.
    - Input a 5 letters room number and Tap **OK**.
  - Add resident's phone number to the room
    - Press a room number to select a room.
    - Press + button and select **Phone number**.
    - Input resident's phone number and Tap **OK**.

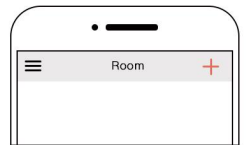

### Enable and check video logs

- Press **Detail** button.
- Press **Video log** and enable it.
- Press **view all** of call log and check video logs.
- Press **Unlock records** of smart lock and check video logs.

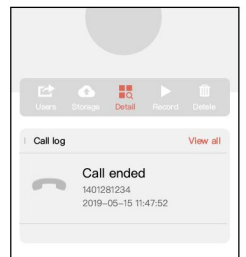

## Placement

### On/In the Wall

- You can mount the door phone directly to the wall.

### With Table Bracket

- Place the door phone on a table for intercom.

### With Floor Stand

- Place the door phone beside the gate.